

IN : INSTRUMENTATION ENGINEERING

Duration: Three Hours

Maximum Marks: 100

Read the following instructions carefully.

1. Do not open the seal of the Question Booklet until you are asked to do so by the invigilator.
2. Take out the **Optical Response Sheet (ORS)** from this Question Booklet **without breaking the seal** and read the instructions printed on the **ORS** carefully.
3. On the right half of the **ORS**, using **ONLY a black ink ball point pen**, (i) darken the bubble corresponding to your test paper code and the appropriate bubble under each digit of your registration number and (ii) write your registration number, your name and name of the examination centre and put your signature at the specified location.
4. This Question Booklet contains **20** pages including blank pages for rough work. After you are permitted to open the seal, please check all pages and report discrepancies, if any, to the invigilator.
5. There are a total of 65 questions carrying 100 marks. All these questions are of objective type. Each question has only **one** correct answer. Questions must be answered on the left hand side of the **ORS** by darkening the appropriate bubble (marked A, B, C, D) using **ONLY a black ink ball point pen** against the question number. **For each question darken the bubble of the correct answer.** More than one answer bubbled against a question will be treated as an incorrect response.
6. Since bubbles darkened by the black ink ball point pen **cannot** be erased, candidates should darken the bubbles in the **ORS very carefully**.
7. Questions Q.1 – Q.25 carry 1 mark each. Questions Q.26 – Q.55 carry 2 marks each. The 2 marks questions include two pairs of common data questions and two pairs of linked answer questions. The answer to the second question of the linked answer questions depends on the answer to the first question of the pair. If the first question in the linked pair is wrongly answered or is unattempted, then the answer to the second question in the pair will not be evaluated.
8. Questions Q.56 – Q.65 belong to General Aptitude (GA) section and carry a total of 15 marks. Questions Q.56 – Q.60 carry 1 mark each, and questions Q.61 – Q.65 carry 2 marks each.
9. Unattempted questions will result in zero mark and wrong answers will result in **NEGATIVE** marks. For all 1 mark questions, $\frac{1}{2}$ mark will be deducted for each wrong answer. For all 2 marks questions, $\frac{2}{3}$ mark will be deducted for each wrong answer. However, in the case of the linked answer question pair, there will be negative marks only for wrong answer to the first question and no negative marks for wrong answer to the second question.
10. Calculator is allowed whereas charts, graph sheets or tables are **NOT** allowed in the examination hall.
11. Rough work can be done on the question paper itself. Blank pages are provided at the end of the question paper for rough work.
12. Before the start of the examination, write your name and registration number in the space provided below using a black ink ball point pen.

Name	ANISH . S . BHARADWAJ .
Registration Number	IN 1 0 3 6 0 3 0

SEAL

SEAL

Q. 1 – Q. 25 carry one mark each.

- Q.1 If $x = \sqrt{-1}$, then the value of x^x is
 (A) $e^{-x/2}$ (B) $e^{x/2}$ (C) x (D) 1
- Q.2 With initial condition $x(1) = 0.5$, the solution of the differential equation,
 $t \frac{dx}{dt} + x = t$ is
 (A) $x = t - \frac{1}{2}$ (B) $x = t^2 - \frac{1}{2}$ (C) $x = \frac{t^2}{2}$ (D) $x = \frac{t}{2}$
- Q.3 Two independent random variables X and Y are uniformly distributed in the interval $[-1, 1]$. The probability that $\max[X, Y]$ is less than $1/2$ is
 (A) $3/4$ (B) $9/16$ (C) $1/4$ (D) $2/3$
- Q.4 The unilateral Laplace transform of $f(t)$ is $\frac{1}{s^2 + s + 1}$. The unilateral Laplace transform of $t f(t)$ is
 (A) $-\frac{s}{(s^2 + s + 1)^2}$ (B) $-\frac{2s + 1}{(s^2 + s + 1)^2}$
 (C) $\frac{s}{(s^2 + s + 1)^2}$ (D) $\frac{2s + 1}{(s^2 + s + 1)^2}$
- Q.5 Given
 $f(z) = \frac{1}{z+1} - \frac{2}{z+3}$. If C is a counterclockwise path in the z -plane such that $|z+1| = 1$, the value of
 $\frac{1}{2\pi j} \oint_C f(z) dz$ is
 (A) -2 (B) -1 (C) 1 (D) 2
- Q.6 The average power delivered to an impedance $(4 - j3) \Omega$ by a current $5 \cos(100\pi t + 100)$ A is
 (A) 44.2 W (B) 50 W (C) 62.5 W (D) 125 W
- Q.7 In the circuit shown below, the current through the inductor is

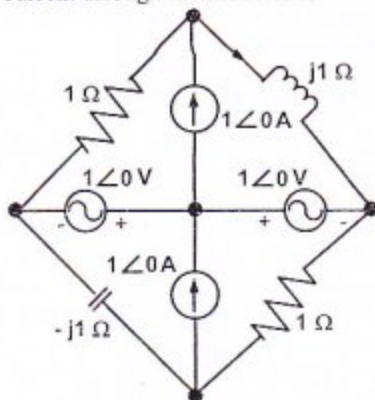

- (A) $\frac{2}{1+j}$ A (B) $\frac{-1}{1+j}$ A (C) $\frac{1}{1+j}$ A (D) 0 A

- Q.8 In the following figure, C_1 and C_2 are ideal capacitors. C_1 has been charged to 12 V before the ideal switch S is closed at $t = 0$. The current $i(t)$ for all t is

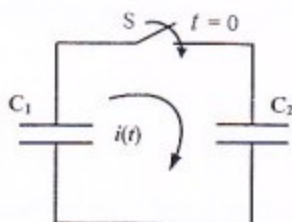

- (A) zero
(B) a step function
(C) an exponentially decaying function
(D) an impulse function
- Q.9 The impedance looking into nodes 1 and 2 in the given circuit is

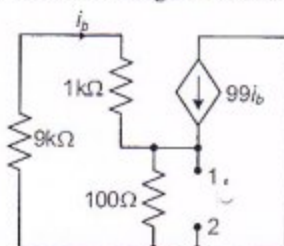

- (A) 50 Ω (B) 100 Ω (C) 5 k Ω (D) 10.1 k Ω
- Q.10 The i - v characteristics of the diode in the circuit given below are

$$i = \begin{cases} \frac{v-0.7}{500} \text{ A, } v \geq 0.7 \text{ V} \\ 0 \text{ A, } v < 0.7 \text{ V} \end{cases}$$

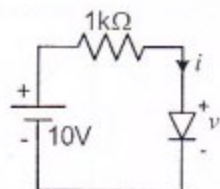

The current in the circuit is

- (A) 10 mA (B) 9.3 mA (C) 6.67 mA (D) 6.2 mA
- Q.11 A system with transfer function

$$G(s) = \frac{(s^2 + 9)(s + 2)}{(s + 1)(s + 3)(s + 4)}$$

is excited by $\sin(\omega t)$. The steady-state output of the system is zero at

- (A) $\omega = 1$ rad/s (B) $\omega = 2$ rad/s
(C) $\omega = 3$ rad/s (D) $\omega = 4$ rad/s

- Q.12 The output Y of a 2-bit comparator is logic 1 whenever the 2-bit input A is greater than the 2-bit input B . The number of combinations for which the output is logic 1, is
 (A) 4 (B) 6 (C) 8 (D) 10
- Q.13 In the sum of products function $f(X, Y, Z) = \sum(2, 3, 4, 5)$, the prime implicants are
 (A) $\bar{X}Y, X\bar{Y}$ (B) $\bar{X}Y, X\bar{Y}\bar{Z}, X\bar{Y}Z$
 (C) $\bar{X}Y\bar{Z}, \bar{X}YZ, X\bar{Y}$ (D) $\bar{X}Y\bar{Z}, \bar{X}YZ, X\bar{Y}\bar{Z}, X\bar{Y}Z$
- Q.14 Consider the given circuit.

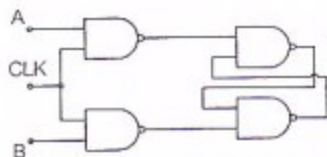

In this circuit, the race around

- (A) does not occur (B) occurs when $CLK = 0$
 (C) occurs when $CLK = 1$ and $A = B = 1$ (D) occurs when $CLK = 1$ and $A = B = 0$
- Q.15 If $x[n] = (1/3)^{|n|} - (1/2)^n u[n]$, then the region of convergence (ROC) of its Z -transform in the Z -plane will be
 (A) $\frac{1}{3} < |z| < 3$ (B) $\frac{1}{3} < |z| < \frac{1}{2}$ (C) $\frac{1}{2} < |z| < 3$ (D) $\frac{1}{3} < |z|$
- Q.16 A capacitive motion transducer circuit is shown. The gap d between the parallel plates of the capacitor is varied as $d(t) = 10^{-3}[1 + 0.1 \sin(1000\pi t)]$ m. If the value of the capacitance is 2pF at $t = 0$ ms, the output voltage V_o at $t = 2$ ms is

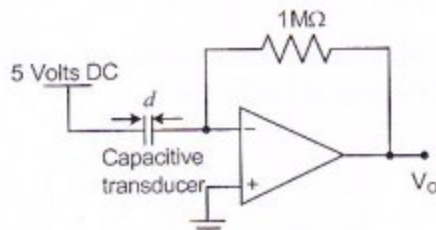

- (A) $\frac{\pi}{2}$ mV (B) π mV (C) 2π mV (D) 4π mV
- Q.17 A psychrometric chart is used to determine
 (A) pH (B) Sound velocity in glasses
 (C) CO_2 concentration (D) Relative humidity

- Q.18 A strain gauge is attached on a cantilever beam as shown. If the base of the cantilever vibrates according to the equation $x(t) = \sin \omega_1 t + \sin \omega_2 t$, where $2 \text{ rad/s} < \omega_1, \omega_2 < 3 \text{ rad/s}$, then the output of the strain gauge is proportional to

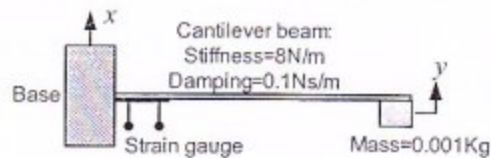

- (A) x (B) $\frac{dx}{dt}$ (C) $\frac{d^2x}{dt^2}$ (D) $\frac{d(x-y)}{dt}$
- Q.19 The transfer function of a Zero-Order-Hold system with sampling interval T is
- (A) $\frac{1}{s}(1 - e^{-Ts})$ (B) $\frac{1}{s}(1 - e^{-Ts})^2$ (C) $\frac{1}{s}e^{-Ts}$ (D) $\frac{1}{s^2}e^{-Ts}$
- Q.20 An LED emitting at $1 \mu\text{m}$ with a spectral width of 50 nm is used in a Michelson interferometer. To obtain a sustained interference, the maximum optical path difference between the two arms of the interferometer is
- (A) $200 \mu\text{m}$ (B) $20 \mu\text{m}$ (C) $1 \mu\text{m}$ (D) 50 nm
- Q.21 Light of wavelength 630 nm in vacuum, falling normally on a biological specimen of thickness $10 \mu\text{m}$, splits into two beams that are polarized at right angles. The refractive index of the tissue for the two polarizations are 1.32 and 1.333 . When the two beams emerge, they are out of phase by
- (A) 0.13° (B) 74.3° (C) 90.0° (D) 128.6°
- Q.22 The responsivity of the PIN photodiode shown is 0.9 A/W . To obtain V_{out} of -1 V for an incident optical power of 1 mW , the value of R to be used is

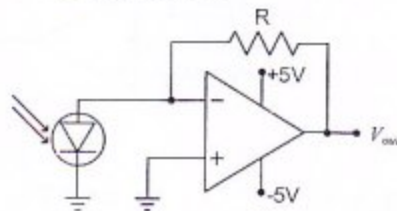

- (A) 0.9Ω (B) 1.1Ω (C) $0.9 \text{ k}\Omega$ (D) $1.1 \text{ k}\Omega$

- Q.23 A periodic voltage waveform observed on an oscilloscope across a load is shown. A permanent magnet moving coil (PMMC) meter connected across the same load reads

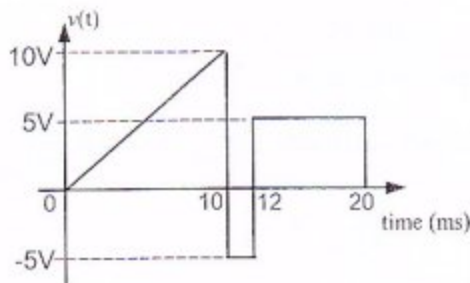

- (A) 4 V (B) 5 V (C) 8 V (D) 10 V
- Q.24 For the circuit shown in the figure, the voltage and current expressions are $v(t) = E_1 \sin(\omega t) + E_3 \sin(3\omega t)$ and $i(t) = I_1 \sin(\omega t - \phi_1) + I_3 \sin(3\omega t - \phi_3) + I_5 \sin(5\omega t)$. The average power measured by the Wattmeter is

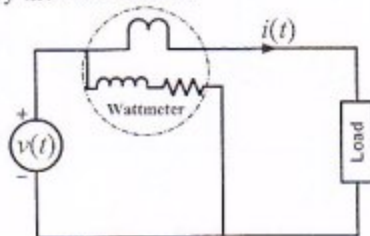

- (A) $\frac{1}{2} E_1 I_1 \cos \phi_1$ (B) $\frac{1}{2} [E_1 I_1 \cos \phi_1 + E_3 I_3 \cos \phi_3 + E_5 I_5]$
- (C) $\frac{1}{2} [E_1 I_1 \cos \phi_1 + E_3 I_3 \cos \phi_3]$ (D) $\frac{1}{2} [E_1 I_1 \cos \phi_1 + E_3 I_1 \cos \phi_1]$
- Q.25 The bridge method commonly used for finding mutual inductance is
- (A) Heaviside Campbell bridge (B) Schering bridge
- (C) De Sauty bridge (D) Wien bridge

Q. 26 to Q. 55 carry two marks each.

- Q.26 A fair coin is tossed till a head appears for the first time. The probability that the number of required tosses is odd, is

- (A) 1/3 (B) 1/2 (C) 2/3 (D) 3/4

- Q.27 Given that

$$A = \begin{bmatrix} -5 & -3 \\ 2 & 0 \end{bmatrix} \text{ and } I = \begin{bmatrix} 1 & 0 \\ 0 & 1 \end{bmatrix}, \text{ the value of } A^3 \text{ is}$$

- (A) $15A + 12I$ (B) $19A + 30I$
- (C) $17A + 15I$ (D) $17A + 21I$
- Q.28 The direction of vector \mathbf{A} is radially outward from the origin, with $|\mathbf{A}| = k r^n$ where $r^2 = x^2 + y^2 + z^2$ and k is a constant. The value of n for which $\nabla \cdot \mathbf{A} = 0$ is

- (A) -2 (B) 2 (C) 1 (D) 0

- Q.29 The maximum value of $f(x) = x^3 - 9x^2 + 24x + 5$ in the interval $[1, 6]$ is
 (A) 21 (B) 25 (C) 41 (D) 46

- Q.30 Consider the differential equation

$$\frac{d^2 y(t)}{dt^2} + 2 \frac{dy(t)}{dt} + y(t) = \delta(t) \text{ with } y(t)|_{t=0^-} = -2 \text{ and } \frac{dy}{dt}|_{t=0^-} = 0.$$

The numerical value of $\frac{dy}{dt}|_{t=0^+}$ is

- (A) -2 (B) -1 (C) 0 (D) 1
- Q.31 If $V_A - V_B = 6 \text{ V}$, then $V_C - V_D$ is

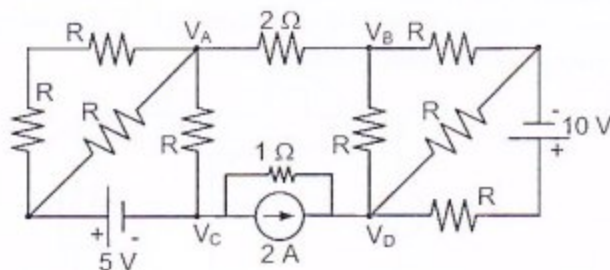

- (A) -5 V (B) 2 V (C) 3 V (D) 6 V
- Q.32 Assuming both the voltage sources are in phase, the value of R for which maximum power is transferred from circuit A to circuit B is

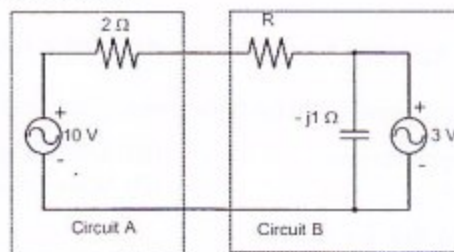

- (A) 0.8Ω (B) 1.4Ω (C) 2Ω (D) 2.8Ω
- Q.33 The voltage gain A_v of the circuit shown below is

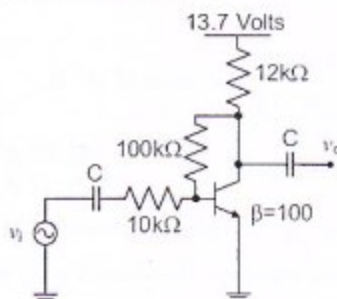

- (A) $|A_v| \approx 200$ (B) $|A_v| \approx 100$ (C) $|A_v| \approx 20$ (D) $|A_v| \approx 10$

Q.34 The state variable description of an LTI system is given by

$$\begin{pmatrix} \dot{x}_1 \\ \dot{x}_2 \\ \dot{x}_3 \end{pmatrix} = \begin{pmatrix} 0 & a_1 & 0 \\ 0 & 0 & a_2 \\ a_3 & 0 & 0 \end{pmatrix} \begin{pmatrix} x_1 \\ x_2 \\ x_3 \end{pmatrix} + \begin{pmatrix} 0 \\ 0 \\ 1 \end{pmatrix} u$$

$$y = \begin{pmatrix} 1 & 0 & 0 \end{pmatrix} \begin{pmatrix} x_1 \\ x_2 \\ x_3 \end{pmatrix}$$

where y is the output and u is the input. The system is controllable for

- (A) $a_1 \neq 0, a_2 = 0, a_3 \neq 0$ (B) $a_1 = 0, a_2 \neq 0, a_3 \neq 0$
 (C) $a_1 = 0, a_2 \neq 0, a_3 = 0$ (D) $a_1 \neq 0, a_2 \neq 0, a_3 = 0$

Q.35 The state transition diagram for the logic circuit shown is

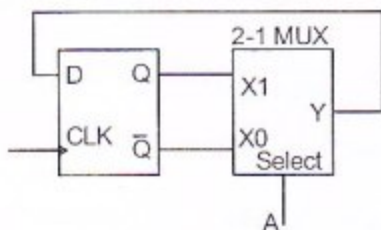

- (A)
- (B)
- (C)
- (D)

Q.36 The Fourier transform of a signal $h(t)$ is $H(j\omega) = (2\cos\omega)(\sin 2\omega)/\omega$. The value of $h(0)$ is

- (A) 1/4 (B) 1/2 (C) 1 (D) 2

Q.37 Let $y[n]$ denote the convolution of $h[n]$ and $g[n]$, where $h[n] = (1/2)^n u[n]$ and $g[n]$ is a causal sequence. If $y[0] = 1$ and $y[1] = 1/2$, then $g[1]$ equals

- (A) 0 (B) 1/2 (C) 1 (D) 3/2

Q.38 The feedback system shown below oscillates at 2 rad/s when

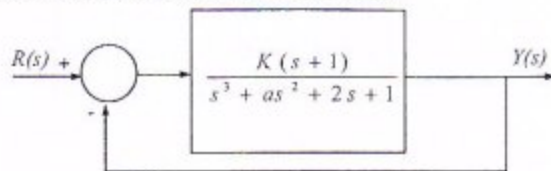

(A) $K = 2$ and $a = 0.75$

(B) $K = 3$ and $a = 0.75$

(C) $K = 4$ and $a = 0.5$

(D) $K = 2$ and $a = 0.5$

Q.39 The circuit shown is a

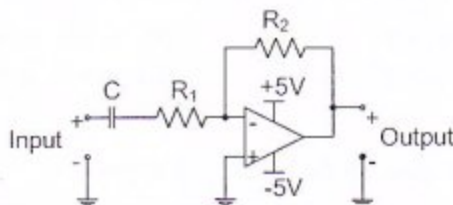

(A) low pass filter with $f_{3dB} = \frac{1}{(R_1 + R_2)C}$ rad/s

(B) high pass filter with $f_{3dB} = \frac{1}{R_1 C}$ rad/s

(C) low pass filter with $f_{3dB} = \frac{1}{R_1 C}$ rad/s

(D) high pass filter with $f_{3dB} = \frac{1}{(R_1 + R_2)C}$ rad/s

Q.40 The input $x(t)$ and output $y(t)$ of a system are related as $y(t) = \int_{-\infty}^t x(\tau) \cos(3\tau) d\tau$. The system is

(A) time-invariant and stable

(B) stable and not time-invariant

(C) time-invariant and not stable

(D) not time-invariant and not stable

Q.41 A double convex lens is used to couple a laser beam of diameter 5 mm into an optical fiber with a numerical aperture of 0.5. The minimum focal length of the lens that should be used in order to focus the entire beam into the fiber is

(A) 1.44 mm

(B) 2.50 mm

(C) 4.33 mm

(D) 5.00 mm

Q.42 An analog voltmeter uses external multiplier settings. With a multiplier setting of 20 k Ω , it reads 440 V and with a multiplier setting of 80 k Ω , it reads 352 V. For a multiplier setting of 40 k Ω , the voltmeter reads

(A) 371 V

(B) 383 V

(C) 394 V

(D) 406 V

Q.43 The open loop transfer function of a unity negative feedback control system is given by

$$G(s) = \frac{150}{s(s+9)(s+25)}$$

The gain margin of the system is

(A) 10.8 dB

(B) 22.3 dB

(C) 34.1 dB

(D) 45.6 dB

- Q.44 A dynamometer arm makes contact with the piezoelectric load cell as shown. The g -constant of the piezoelectric material is $50 \times 10^{-3} \text{ Vm/N}$ and the surface area of the load cell is 4 cm^2 . If a torque $\tau = 20 \text{ Nm}$ is applied to the dynamometer, the output voltage V_o of the load cell is

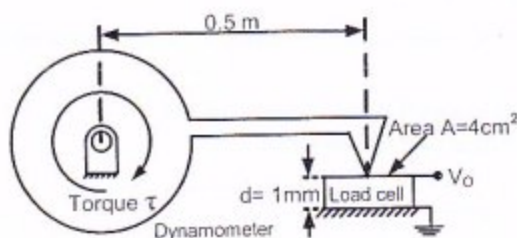

- (A) 4 V (B) 5 V (C) 10 V (D) 16 V
- Q.45 Water (density: 1000 kgm^{-3}) stored in a cylindrical drum of diameter 1 m is emptied through a horizontal pipe of diameter 0.05 m. A pitot-static tube is placed inside the pipe facing the flow. At the time when the difference between the stagnation and static pressures measured by the pitot-static tube is 10 kPa, the rate of reduction in water level in the drum is,

- (A) $\frac{1}{200\sqrt{5}} \text{ ms}^{-1}$ (B) $\frac{1}{75\sqrt{10}} \text{ ms}^{-1}$ (C) $\frac{1}{50\sqrt{10}} \text{ ms}^{-1}$ (D) $\frac{1}{40\sqrt{5}} \text{ ms}^{-1}$

- Q.46 A U-tube manometer of tube diameter D is filled with a liquid of zero viscosity. If the volume of the liquid filled is V , the natural frequency of oscillations in the liquid level about its mean position, due to small perturbations, is

- (A) $\frac{D}{2\sqrt{2\pi}} \sqrt{\frac{g}{V}}$ (B) $\frac{2\sqrt{2}}{\sqrt{\pi}} \frac{\sqrt{gV}}{D^2}$ (C) $\frac{1}{2\sqrt{\pi}} \frac{\sqrt{gD}}{V^{1/3}}$ (D) $\frac{1}{\sqrt{\pi}} \sqrt{\frac{g}{D}}$

- Q.47 The open loop transfer function of a unity gain negative feedback control system is given by $G(s) = \frac{s^2 + 4s + 8}{s(s+2)(s+8)}$. The angle θ , at which the root locus approaches the zeros of the system, satisfies

- (A) $|\theta| = \pi - \tan^{-1}\left(\frac{1}{4}\right)$ (B) $|\theta| = \frac{3\pi}{4} - \tan^{-1}\left(\frac{1}{3}\right)$
 (C) $|\theta| = \frac{\pi}{2} - \tan^{-1}\left(\frac{1}{4}\right)$ (D) $|\theta| = \frac{\pi}{4} - \tan^{-1}\left(\frac{1}{3}\right)$

Common Data Questions

Common Data for Questions 48 and 49:

With 10 V dc connected at port A in the linear nonreciprocal two-port network shown below, the following were observed:

- (i) 1 Ω connected at port B draws a current of 3 A
 (ii) 2.5 Ω connected at port B draws a current of 2 A

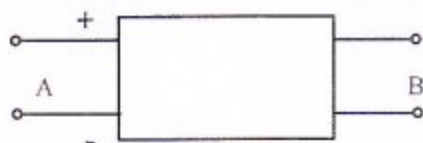

- Q.48 With 10 V dc connected at port A, the current drawn by 7 Ω connected at port B is
 (A) 3/7 A (B) 5/7 A (C) 1 A (D) 9/7 A
- Q.49 For the same network, with 6 V dc connected at port A, 1 Ω connected at port B draws 7/3 A. If 8 V dc is connected to port A, the open circuit voltage at port B is
 (A) 6 V (B) 7 V (C) 8 V (D) 9 V

Common Data for Questions 50 and 51:

The deflection profile $y(x)$ of a cantilever beam due to application of a point force F (in Newton), as a function of distance x from its base, is given by $y(x) = 0.001 F x^2 \left(1 - \frac{x}{3}\right)$ m. The angular deformation θ at the end of the cantilever is measured by reflecting a laser beam off a mirror M as shown in the figure.

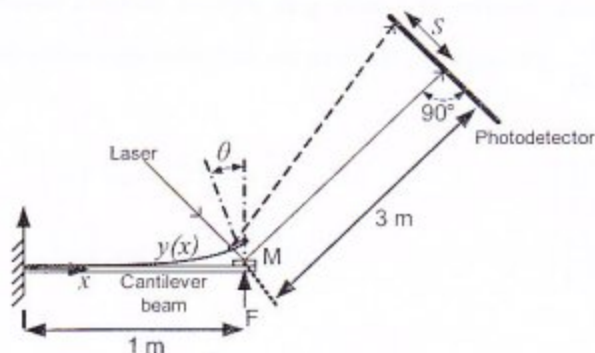

- Q.50 The translation S of the spot of laser light on the photodetector when a force of $F = 1$ N is applied to the cantilever is
 (A) 1 mm (B) 3 mm (C) 6 mm (D) 12 mm
- Q.51 If linear variable differential transformers (LVDTs) are mounted at $x = \frac{1}{2}$ m and $x = \frac{1}{4}$ m on the cantilever to measure the effect of time varying forces, the ratio of their outputs is
 (A) 12/7 (B) 40/11 (C) 176/23 (D) 112/15

Linked Answer Questions

Statement for Linked Answer Questions 52 and 53:

The transfer function of a compensator is given as

$$G_c(s) = \frac{s+a}{s+b}$$

Q.52 $G_c(s)$ is a lead compensator if

(A) $a=1, b=2$

(C) $a=-3, b=-1$

(B) $a=3, b=2$

(D) $a=3, b=1$

Q.53 The phase of the above lead compensator is maximum at

(A) $\sqrt{2}$ rad/s

(B) $\sqrt{3}$ rad/s

(C) $\sqrt{6}$ rad/s

(D) $1/\sqrt{3}$ rad/s

Statement for Linked Answer Questions 54 and 55:

In the circuit shown, the three voltmeter readings are $V_1 = 220$ V, $V_2 = 122$ V, $V_3 = 136$ V.

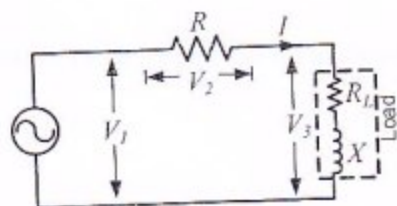

Q.54 The power factor of the load is

(A) 0.45

(B) 0.50

(C) 0.55

(D) 0.60

Q.55 If $R_L = 5 \Omega$, the approximate power consumption in the load is

(A) 700 W

(B) 750 W

(C) 800 W

(D) 850 W

General Aptitude (GA) Questions (Compulsory)**Q. 56 – Q. 60 carry one mark each.**

- Q.56 Choose the most appropriate alternative from the options given below to complete the following sentence:

If the tired soldier wanted to lie down, he ___ the mattress out on the balcony.

- (A) should take
(B) shall take
(C) should have taken
(D) will have taken

- Q.57 If $(1.001)^{1259} = 3.52$ and $(1.001)^{2062} = 7.85$, then $(1.001)^{3321} =$

- (A) 2.23 (B) 4.33 (C) 11.37 (D) 27.64

- Q.58 One of the parts (A, B, C, D) in the sentence given below contains an ERROR. Which one of the following is INCORRECT?

I requested that he should be given the driving test today instead of tomorrow.

- (A) requested that
(B) should be given
(C) the driving test
(D) instead of tomorrow

- Q.59 Which one of the following options is the closest in meaning to the word given below?

Latitude

- (A) Eligibility (B) Freedom (C) Coercion (D) Meticulousness

- Q.60 Choose the most appropriate word from the options given below to complete the following sentence:

Given the seriousness of the situation that he had to face, his ___ was impressive.

- (A) beggary (B) nomenclature (C) jealousy (D) nonchalance

Q. 61 - Q. 65 carry two marks each.

- Q.61 Raju has 14 currency notes in his pocket consisting of only Rs. 20 notes and Rs. 10 notes. The total money value of the notes is Rs. 230. The number of Rs. 10 notes that Raju has is

- (A) 5 (B) 6 (C) 9 (D) 10

- Q.62 One of the legacies of the Roman legions was discipline. In the legions, military law prevailed and discipline was brutal. Discipline on the battlefield kept units obedient, intact and fighting, even when the odds and conditions were against them.

Which one of the following statements best sums up the meaning of the above passage?

- (A) Thorough regimentation was the main reason for the efficiency of the Roman legions even in adverse circumstances.
(B) The legions were treated inhumanly as if the men were animals.
(C) Discipline was the armies' inheritance from their seniors.
(D) The harsh discipline to which the legions were subjected to led to the odds and conditions being against them.
- Q.63 A and B are friends. They decide to meet between 1 PM and 2 PM on a given day. There is a condition that whoever arrives first will not wait for the other for more than 15 minutes. The probability that they will meet on that day is
- (A) $1/4$ (B) $1/16$ (C) $7/16$ (D) $9/16$
- Q.64 The data given in the following table summarizes the monthly budget of an average household.

Category	Amount (Rs.)
Food	4000
Clothing	1200
Rent	2000
Savings	1500
Other expenses	1800

The approximate percentage of the monthly budget **NOT** spent on savings is

- (A) 10% (B) 14% (C) 81% (D) 86%
- Q.65 There are eight bags of rice looking alike, seven of which have equal weight and one is slightly heavier. The weighing balance is of unlimited capacity. Using this balance, the minimum number of weighings required to identify the heavier bag is
- (A) 2 (B) 3 (C) 4 (D) 8

END OF THE QUESTION PAPER